

_AKTIONSZEITRAUM: 01.09. – 25.10.2024

TIGER-TEC® GOLD DREHSORTEN

WPP10G, WPP20G, WPP30G

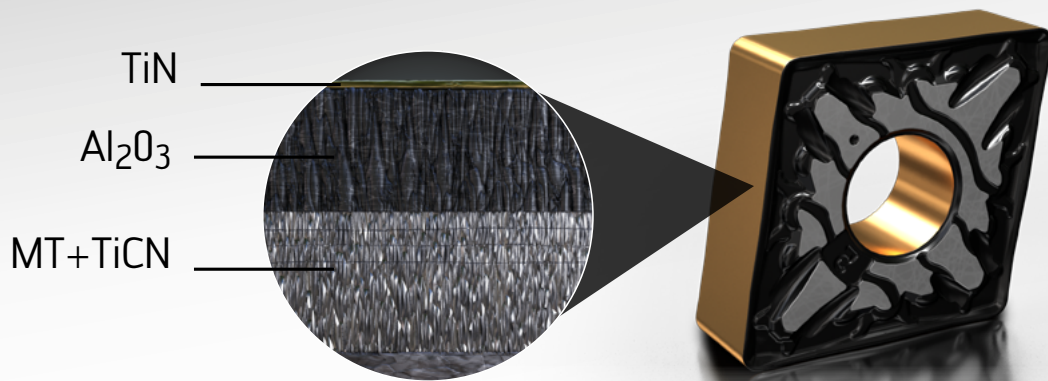

Ihr Vorteil

60%

**TIGER-TEC® GOLD – STARK IN STAHL UND
GEGEN VERSCHLEISS.**

- Maximale Prozesssicherheit
- Hohe Flexibilität durch Benchmarkgeometrien
- + 50 % nachgewiesene Leistungssteigerung

 **WALTER**

Stark in Stahl und gegen Verschleiß.

DIE GEOMETRIE

- Negative Geometrien: FP5, MP3, MP5, MU5, RP5, RP7
- Positive Geometrien: FP4, MP4, RP4

DIE SORTE

- Neue Tiger-tec® Gold Beschichtung: feinkolumnares, hochtexturiertes MT-TiCN – widerstandsfähig gegen Freiflächenverschleiß
- Mehrlagige MT-TiCN-Struktur verbessert die elastische Eigenschaft der Kristalle
- Hochtexturiertes Al₂O₃ – für höheren Widerstand gegen Kolkverschleiß
- Mehrstufige Nachbehandlung für glatte Spanfläche, reduzierte Reibung und verbesserte Zähigkeit

DIE ANWENDUNG

WPP10G

- Verschleißfest bei kontinuierlichem Schnitt bis zu leichten Schnittunterbrechungen
- Hauptanwendung: Stahl ISO P10;
Nebenanwendung: Gusseisen ISO K20

WPP20G

- Universalsorte mit hoher Standzeit und Prozesssicherheit für ca. 50 % aller Einsatzfälle
- Hauptanwendung: Stahl ISO P20;
Nebenanwendung: Gusseisen ISO K30

WPP30G

- Zähle Sorte für Schnittunterbrechungen, instabile oder ungünstige Bedingungen
- Hauptanwendung: Stahl ISO P30;
Nebenanwendung: Gusseisen ISO K40 und nichtrostender Stahl ISO M20

Hochtexturiertes MT-TiCN –
maximaler Widerstand gegen
Freiflächenverschleiß



Hochtexturiertes Al₂O₃
– höherer Widerstand
gegen Kolkverschleiß



Einzigartige,
mehrlagige MT-TiCN –
höhere Zähigkeit

Mehrstufige Nachbehandlung –
glatte Spanfläche, reduzierte Reibung
und verbesserte Zähigkeit

Tiger-tec®Gold

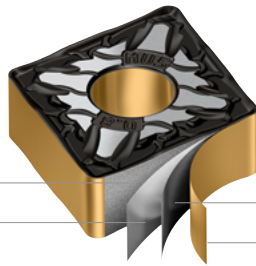

Hartmetall

MT-TiCN – hochtexturiert

Al₂O₃ – hochtexturiert

Gold-Toplayer

Abb.: Schichtaufbau TIG

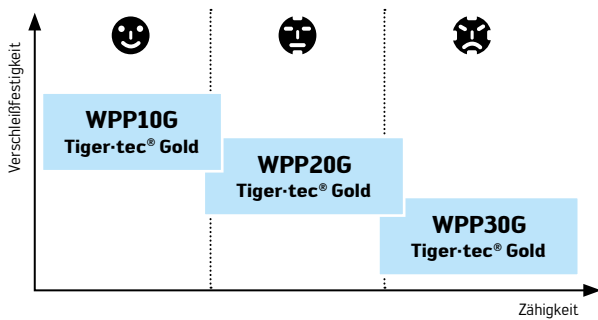

ANWENDUNGSBEISPIEL

Getriebewelle –
Innenbearbeitung Ø 29 mm

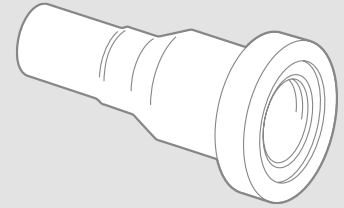

Werkstoff: 18MnCrS5 / DIN 1.8720

Festigkeit: 580 N/mm²

Werkzeug: E20S-SDUCR11-R

Wendeschneidplatte: DCMT11T304-FP4 WPP20G

Schnittdaten

	Wettbewerber ISO P20	Walter WPP20G Tiger-tec® Gold
v _c (m/min)	320	320
f (mm)	0,13	0,13
a _p (mm)	0,4	0,4
Kühlung	Emulsion 15 bar	Emulsion 15 bar
Standzeit (Stck.)	170	250

Vergleich: Standmenge

+ 47%

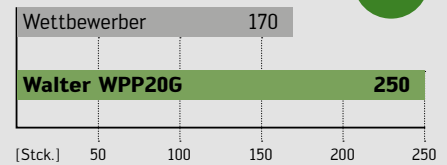

Konventionelles TiCN

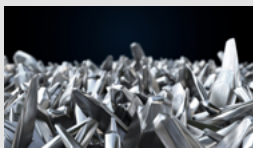

Tiger-tec® Gold
MT-TiCN –
hochtexturiert



Hohe Verschleißfestigkeit
und Standzeitsteigerung

Tiger-tec® Gold

Al₂O₃ –
hochtexturiert

MT-TiCN –
hochtexturiert

Hartmetall

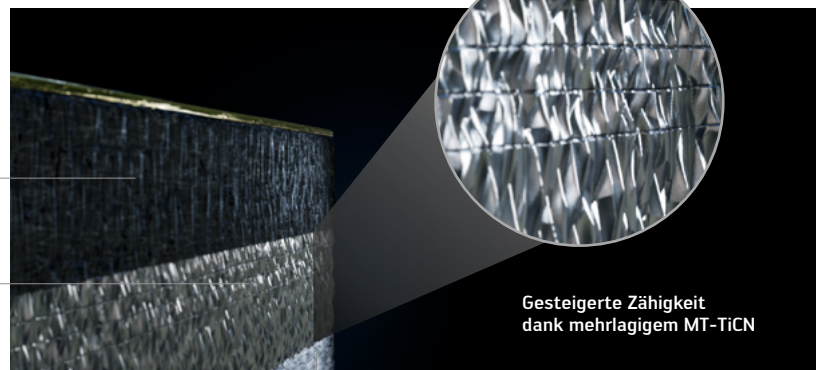

Gesteigerte Zähigkeit
dank mehrlagigem MT-TiCN

IHRE VORTEILE

- Hohe Produktivität und Prozesssicherheit dank mehrstufiger Nachbehandlung und einzigartiger, mehrlagiger MT-TiCN-Struktur
- Sorten und Benchmark-Geometrien für kurze Späne mit flexibler Einsetzbarkeit
- Hohe Wirtschaftlichkeit durch hochtexturierte Tiger-tec® Gold Beschichtung – durchschnittliche Standzeitsteigerung von rund 50 %

Bestellen Sie jetzt und nutzen Sie den Aktionsrabatt!



	P	M	K	N	S	H	O
WPP10G	●●		●				
WPP20G	●●		●				
WPP30G	●●	●	●				

Wendeschneidplatte

FP5 - Schichten

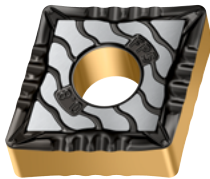

Produktbeschreibung	r [mm]	f [mm]	a _p [mm]	Aktionspreis*	Stückzahl
CNMG120404-FP5PDW WPP10G	0,4	0.04 - 0.20	0.1 - 1.5	5,78€	
CNMG120404-FP5PDW WPP20G	0,4	0.04 - 0.20	0.1 - 1.5	5,78€	
CNMG120408-FP5PDW WPP10G	0,8	0.08 - 0.25	0.2 - 2.0	5,78€	
CNMG120408-FP5PDW WPP20G	0,8	0.08 - 0.25	0.2 - 2.0	5,78€	
DNMG110404-FP5PDW WPP10G	0,4	0.04 - 0.20	0.1 - 1.5	6,08€	
DNMG110404-FP5PDW WPP20G	0,4	0.04 - 0.20	0.1 - 1.5	6,08€	
DNMG110408-FP5PDW WPP10G	0,8	0.08 - 0.25	0.2 - 2.0	6,08€	
DNMG110408-FP5PDW WPP20G	0,8	0.08 - 0.25	0.2 - 2.0	6,08€	
DNMG150604-FP5PDW WPP10G	0,4	0.05 - 0.20	0.1 - 1.5	8,04€	
DNMG150604-FP5PDW WPP20G	0,4	0.05 - 0.20	0.1 - 1.5	8,04€	
DNMG150608-FP5PDW WPP10G	0,8	0.08 - 0.25	0.2 - 2.0	8,04€	
DNMG150608-FP5PDW WPP20G	0,8	0.08 - 0.25	0.2 - 2.0	8,04€	
TNMG160404-FP5PDW WPP10G	0,4	0.04 - 0.20	0.1 - 1.5	5,08€	
TNMG160404-FP5PDW WPP20G	0,4	0.04 - 0.20	0.1 - 1.5	5,08€	
TNMG160408-FP5PDW WPP10G	0,8	0.08 - 0.25	0.2 - 2.0	5,08€	
TNMG160408-FP5PDW WPP20G	0,8	0.08 - 0.25	0.2 - 2.0	5,08€	
VNMG160404-FP5PDW WPP10G	0,4	0.04 - 0.22	0.1 - 1.5	10,56€	
VNMG160404-FP5PDW WPP20G	0,4	0.04 - 0.22	0.1 - 1.5	10,56€	
VNMG160408-FP5PDW WPP10G	0,8	0.08 - 0.25	0.2 - 2.0	10,56€	
VNMG160408-FP5PDW WPP20G	0,8	0.08 - 0.25	0.2 - 2.0	10,56€	
WNMG080404-FP5PDW WPP10G	0,4	0.05 - 0.20	0.1 - 1.5	6,41€	
WNMG080404-FP5PDW WPP20G	0,4	0.05 - 0.20	0.1 - 1.5	6,41€	
WNMG080408-FP5PDW WPP10G	0,8	0.08 - 0.25	0.2 - 2.0	6,41€	
WNMG080408-FP5PDW WPP20G	0,8	0.08 - 0.25	0.2 - 2.0	6,41€	

Absender

Firma

Name

Straße / Hausnr.

PLZ / Ort

Dieses Formular nutzen und gleich per E-Mail bestellen!



Senden

In Kooperation mit:

Aktionszeitraum: 8 Wochen bzw. solange der Vorrat reicht. Aktionsware ist vom Umtausch ausgeschlossen.

* Kundenvorteil (60 %) bereits berücksichtigt. Abbildungen ähnlich. Änderungen vorbehalten. Empfohlener Verkaufspreis.

Bestellen Sie jetzt und nutzen Sie den Aktionsrabatt!



	P	M	K	N	S	H	O
WPP10G	●●		●				
WPP20G	●●		●				
WPP30G	●●	●	●				

Wendeschneidplatte

MP3 - Mittlere Bearbeitung



Produktbeschreibung	r [mm]	f [mm]	a _p [mm]	Aktionspreis*	Stückzahl
CNMG120404-MP3PDW WPP10G	0,4	0.08 - 0.22	0.3 - 2.5	5,78€	
CNMG120404-MP3PDW WPP20G	0,4	0.08 - 0.22	0.3 - 2.5	5,78€	
CNMG120408-MP3PDW WPP10G	0,8	0.12 - 0.32	0.6 - 3.2	5,78€	
CNMG120408-MP3PDW WPP20G	0,8	0.12 - 0.32	0.6 - 3.2	5,78€	
CNMG120412-MP3PDW WPP10G	1,2	0.16 - 0.40	0.8 - 3.5	5,78€	
CNMG120412-MP3PDW WPP20G	1,2	0.16 - 0.40	0.8 - 3.5	5,78€	
DNMG110404-MP3PDW WPP10G	0,4	0.08 - 0.22	0.3 - 2.2	6,08€	
DNMG110404-MP3PDW WPP20G	0,4	0.08 - 0.22	0.3 - 2.2	6,08€	
DNMG110408-MP3PDW WPP10G	0,8	0.12 - 0.32	0.6 - 3.0	6,08€	
DNMG110408-MP3PDW WPP20G	0,8	0.12 - 0.32	0.6 - 3.0	6,08€	
DNMG150604-MP3PDW WPP10G	0,4	0.08 - 0.22	0.3 - 2.5	8,04€	
DNMG150604-MP3PDW WPP20G	0,4	0.08 - 0.22	0.3 - 2.5	8,04€	
DNMG150608-MP3PDW WPP10G	0,8	0.12 - 0.32	0.6 - 3.2	8,04€	
DNMG150608-MP3PDW WPP20G	0,8	0.12 - 0.32	0.6 - 3.2	8,04€	
TNMG160404-MP3PDW WPP20G	0,4	0.08 - 0.22	0.3 - 2.2	5,08€	
TNMG160408-MP3PDW WPP10G	0,8	0.12 - 0.32	0.6 - 3.0	5,08€	
TNMG160408-MP3PDW WPP20G	0,8	0.12 - 0.32	0.6 - 3.0	5,08€	
VNMG160404-MP3PDW WPP10G	0,4	0.08 - 0.22	0.3 - 2.2	10,56€	
VNMG160404-MP3PDW WPP20G	0,4	0.08 - 0.22	0.3 - 2.2	10,56€	
VNMG160408-MP3PDW WPP10G	0,8	0.12 - 0.32	0.6 - 3.0	10,56€	
VNMG160408-MP3PDW WPP20G	0,8	0.12 - 0.32	0.6 - 3.0	10,56€	

Absender

Firma

Name

Straße / Hausnr.

PLZ / Ort

Dieses Formular nutzen und gleich per E-Mail bestellen!



Senden

In Kooperation mit:

Aktionszeitraum: 8 Wochen bzw. solange der Vorrat reicht. Aktionsware ist vom Umtausch ausgeschlossen.

* Kundenvorteil (60 %) bereits berücksichtigt. Abbildungen ähnlich. Änderungen vorbehalten. Empfohlener Verkaufspreis.

Bestellen Sie jetzt und nutzen Sie den Aktionsrabatt!



	P	M	K	N	S	H	O
WPP10G	●	●	●	●	●	●	●
WPP20G	●	●	●	●	●	●	●
WPP30G	●	●	●	●	●	●	●

Wendeschneidplatte

MP5 - Mittlere Bearbeitung



Produktbeschreibung	r [mm]	f [mm]	a _p [mm]	Aktionspreis*	Stückzahl
CNMG120404-MP5PDW WPP10G	0,4	0.16 - 0.25	0.5 - 4.0	5,78€	
CNMG120404-MP5PDW WPP20G	0,4	0.16 - 0.25	0.5 - 4.0	5,78€	
CNMG120408-MP5PDW WPP10G	0,8	0.18 - 0.40	0.6 - 5.0	5,78€	
CNMG120408-MP5PDW WPP20G	0,8	0.18 - 0.40	0.6 - 5.0	5,78€	
CNMG120408-MP5PDW WPP30G	0,8	0.18 - 0.40	0.6 - 5.0	5,78€	
CNMG120412-MP5PDW WPP10G	1,2	0.20 - 0.45	1.0 - 5.0	5,78€	
CNMG120412-MP5PDW WPP20G	1,2	0.20 - 0.45	1.0 - 5.0	5,78€	
CNMG120412-MP5PDW WPP30G	1,2	0.20 - 0.45	1.0 - 5.0	5,78€	
CNMG160608-MP5PDW WPP10G	0,8	0.25 - 0.40	0.8 - 7.0	9,18€	
CNMG160608-MP5PDW WPP20G	0,8	0.25 - 0.40	0.8 - 7.0	9,18€	
CNMG160612-MP5PDW WPP10G	1,2	0.30 - 0.50	1.0 - 7.0	9,18€	
CNMG160612-MP5PDW WPP20G	1,2	0.30 - 0.50	1.0 - 7.0	9,18€	
DNMG110408-MP5PDW WPP10G	0,8	0.18 - 0.35	0.6 - 4.0	6,08€	
DNMG110408-MP5PDW WPP20G	0,8	0.18 - 0.35	0.6 - 4.0	6,08€	
DNMG150604-MP5PDW WPP10G	0,4	0.16 - 0.25	0.5 - 4.0	8,04€	
DNMG150604-MP5PDW WPP20G	0,4	0.16 - 0.25	0.5 - 4.0	8,04€	
DNMG150608-MP5PDW WPP10G	0,8	0.18 - 0.35	0.6 - 5.0	8,04€	
DNMG150608-MP5PDW WPP20G	0,8	0.18 - 0.35	0.6 - 5.0	8,04€	
DNMG150612-MP5PDW WPP10G	1,2	0.20 - 0.40	1.0 - 5.0	8,04€	
DNMG150612-MP5PDW WPP20G	1,2	0.20 - 0.40	1.0 - 5.0	8,04€	
TNMG160404-MP5PDW WPP20G	0,4	0.16 - 0.25	0.5 - 4.0	5,08€	
TNMG160408-MP5PDW WPP10G	0,8	0.18 - 0.35	0.6 - 4.0	5,08€	
TNMG160408-MP5PDW WPP20G	0,8	0.18 - 0.35	0.6 - 4.0	5,08€	
VNMG160404-MP5PDW WPP20G	0,4	0.10 - 0.18	0.5 - 2.0	10,56€	
VNMG160408-MP5PDW WPP20G	0,8	0.18 - 0.35	0.6 - 4.0	10,56€	
WNMG080404-MP5PDW WPP10G	0,4	0.16 - 0.25	0.5 - 4.0	6,41€	
WNMG080404-MP5PDW WPP20G	0,4	0.16 - 0.25	0.5 - 4.0	6,41€	
WNMG080408-MP5PDW WPP10G	0,8	0.18 - 0.40	0.6 - 5.0	6,41€	
WNMG080408-MP5PDW WPP20G	0,8	0.18 - 0.40	0.6 - 5.0	6,41€	
WNMG080408-MP5PDW WPP30G	0,8	0.18 - 0.40	0.6 - 5.0	6,41€	
WNMG080412-MP5PDW WPP10G	1,2	0.20 - 0.45	1.0 - 5.0	6,41€	
WNMG080412-MP5PDW WPP20G	1,2	0.20 - 0.45	1.0 - 5.0	6,41€	
WNMG080412-MP5PDW WPP30G	1,2	0.20 - 0.45	1.0 - 5.0	6,41€	

Absender

Firma

Name

Straße / Hausnr.

PLZ / Ort

Dieses Formular nutzen und gleich per E-Mail bestellen!



Senden

In Kooperation mit:

Bestellen Sie jetzt und nutzen Sie den Aktionsrabatt!



	P	M	K	N	S	H	O
WPP10G	●●		●				
WPP20G	●●		●				
WPP30G	●●	●	●				

Wendeschneidplatte

MU5 - Mittlere Bearbeitung



Produktbeschreibung	r [mm]	f [mm]	a _p [mm]	Aktionspreis*	Stückzahl
CNMG120408-MU5PDW WPP10G	0,8	0.15 - 0.40	0.6 - 5.0	5,78€	
CNMG120408-MU5PDW WPP20G	0,8	0.15 - 0.40	0.6 - 5.0	5,78€	
CNMG120412-MU5PDW WPP10G	1,2	0.20 - 0.50	1.0 - 5.0	5,78€	
CNMG120412-MU5PDW WPP20G	1,2	0.20 - 0.50	1.0 - 5.0	5,78€	
DNMG150608-MU5PDW WPP10G	0,8	0.18 - 0.35	0.6 - 5.0	8,04€	
DNMG150608-MU5PDW WPP20G	0,8	0.18 - 0.35	0.6 - 5.0	8,04€	
DNMG150612-MU5PDW WPP10G	1,2	0.20 - 0.45	1.0 - 5.0	8,04€	
DNMG150612-MU5PDW WPP20G	1,2	0.20 - 0.45	1.0 - 5.0	8,04€	
TNMG160404-MU5PDW WPP20G	0,4	0.15 - 0.30	0.5 - 4.0	5,08€	
TNMG160408-MU5PDW WPP20G	0,8	0.18 - 0.35	0.6 - 4.0	5,08€	
WNMG080408-MU5PDW WPP10G	0,8	0.15 - 0.40	0.6 - 5.0	6,41€	
WNMG080408-MU5PDW WPP20G	0,8	0.15 - 0.40	0.6 - 5.0	6,41€	
WNMG080412-MU5PDW WPP10G	1,2	0.20 - 0.50	1.0 - 5.0	6,41€	
WNMG080412-MU5PDW WPP20G	1,2	0.20 - 0.50	1.0 - 5.0	6,41€	

Absender

Firma

Name

Straße / Hausnr.

PLZ / Ort

Dieses Formular nutzen und gleich per E-Mail bestellen!



Senden

In Kooperation mit:

Bestellen Sie jetzt und nutzen Sie den Aktionsrabatt!



	P	M	K	N	S	H	O
WPP10G	●		●				
WPP20G	●		●				
WPP30G	●	●	●				

Wendeschneidplatte

RP5 - Schruppen



Produktbeschreibung	r [mm]	f [mm]	a _p [mm]	Aktionspreis*	Stückzahl
CNMG120408-RP5PDW WPP10G	0,8	0.20 - 0.40	0.8 - 6.0	5,78€	
CNMG120408-RP5PDW WPP20G	0,8	0.20 - 0.40	0.8 - 6.0	5,78€	
CNMG120408-RP5PDW WPP30G	0,8	0.20 - 0.40	0.8 - 6.0	5,78€	
CNMG120412-RP5PDW WPP10G	1,2	0.25 - 0.60	1.0 - 6.0	5,78€	
CNMG120412-RP5PDW WPP20G	1,2	0.25 - 0.60	1.0 - 6.0	5,78€	
CNMG120412-RP5PDW WPP30G	1,2	0.25 - 0.60	1.0 - 6.0	5,78€	
CNMG160612-RP5PDW WPP10G	1,2	0.35 - 0.65	1.2 - 8.0	9,18€	
CNMG160612-RP5PDW WPP20G	1,2	0.35 - 0.65	1.2 - 8.0	9,18€	
CNMG160612-RP5PDW WPP30G	1,2	0.35 - 0.65	1.2 - 8.0	9,18€	
CNMG160616-RP5PDW WPP10G	1,6	0.40 - 0.70	1.6 - 8.0	9,18€	
CNMG160616-RP5PDW WPP20G	1,6	0.40 - 0.70	1.6 - 8.0	9,18€	
CNMG160616-RP5PDW WPP30G	1,6	0.40 - 0.70	1.6 - 8.0	9,18€	
CNMG190612-RP5PDW WPP20G	1,2	0.30 - 0.70	1.2 - 10.	12,84€	
CNMG190612-RP5PDW WPP30G	1,2	0.30 - 0.70	1.2 - 10.	12,84€	
CNMG190616-RP5PDW WPP20G	1,6	0.35 - 0.80	1.6 - 10.	12,84€	
CNMG190616-RP5PDW WPP30G	1,6	0.35 - 0.80	1.6 - 10.	12,84€	
DNMG150608-RP5PDW WPP10G	0,8	0.15 - 0.35	0.8 - 5.0	8,04€	
DNMG150608-RP5PDW WPP20G	0,8	0.15 - 0.35	0.8 - 5.0	8,04€	
DNMG150608-RP5PDW WPP30G	0,8	0.15 - 0.35	0.8 - 5.0	8,04€	
DNMG150612-RP5PDW WPP10G	1,2	0.20 - 0.55	1.0 - 5.0	8,04€	
DNMG150612-RP5PDW WPP20G	1,2	0.20 - 0.55	1.0 - 5.0	8,04€	
WNMG080408-RP5PDW WPP10G	0,8	0.20 - 0.40	0.8 - 6.0	6,41€	
WNMG080408-RP5PDW WPP20G	0,8	0.20 - 0.40	0.8 - 6.0	6,41€	
WNMG080408-RP5PDW WPP30G	0,8	0.20 - 0.40	0.8 - 6.0	6,41€	
WNMG080412-RP5PDW WPP10G	1,2	0.25 - 0.60	1.0 - 6.0	6,41€	
WNMG080412-RP5PDW WPP20G	1,2	0.25 - 0.60	1.0 - 6.0	6,41€	
WNMG080412-RP5PDW WPP30G	1,2	0.25 - 0.60	1.0 - 6.0	6,41€	

RP7 - Schruppen



CNMG120408-RP7PDW WPP10G	0,8	0.18 - 0.40	0.8 - 5.0	5,78€	
CNMG120408-RP7PDW WPP20G	0,8	0.18 - 0.40	0.8 - 5.0	5,78€	
CNMG120408-RP7PDW WPP30G	0,8	0.18 - 0.40	0.8 - 5.0	5,78€	
CNMG120412-RP7PDW WPP10G	1,2	0.25 - 0.50	1.2 - 5.0	5,78€	
CNMG120412-RP7PDW WPP20G	1,2	0.25 - 0.50	1.2 - 5.0	5,78€	
CNMG120412-RP7PDW WPP30G	1,2	0.25 - 0.50	1.2 - 5.0	5,78€	
CNMG160612-RP7PDW WPP10G	1,2	0.35 - 0.60	1.2 - 6.0	9,18€	
CNMG160612-RP7PDW WPP20G	1,2	0.35 - 0.60	1.2 - 6.0	9,18€	
CNMG160612-RP7PDW WPP30G	1,2	0.35 - 0.60	1.2 - 6.0	9,18€	

Absender

Firma

Name

Straße / Hausnr.

PLZ / Ort

Dieses Formular nutzen und gleich per E-Mail bestellen!



Senden

In Kooperation mit:

Aktionszeitraum: 8 Wochen bzw. solange der Vorrat reicht. Aktionsware ist vom Umtausch ausgeschlossen.

* Kundenvorteil (60 %) bereits berücksichtigt. Abbildungen ähnlich. Änderungen vorbehalten. Empfohlener Verkaufspreis.

Bestellen Sie jetzt und nutzen Sie den Aktionsrabatt!



	P	M	K	N	S	H	O
WPP10G	●●		●				
WPP20G	●●		●				
WPP30G	●●	●	●				

Wendeschneidplatte

FP4 - Schlichten

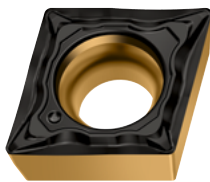

Produktbeschreibung	r [mm]	f [mm]	a _p [mm]	Aktionspreis*	Stückzahl
CCMT060202-FP4PDW WPP10G	0,2	0.04 - 0.12	0.1 - 1.0	4,00€	
CCMT060202-FP4PDW WPP20G	0,2	0.04 - 0.12	0.1 - 1.0	4,00€	
CCMT060204-FP4PDW WPP10G	0,4	0.05 - 0.16	0.1 - 1.5	4,00€	
CCMT060204-FP4PDW WPP20G	0,4	0.05 - 0.16	0.1 - 1.5	4,00€	
CCMT09T304-FP4PDW WPP10G	0,4	0.05 - 0.16	0.1 - 1.5	4,66€	
CCMT09T304-FP4PDW WPP20G	0,4	0.05 - 0.16	0.1 - 1.5	4,66€	
CCMT09T308-FP4PDW WPP10G	0,8	0.08 - 0.20	0.1 - 1.5	4,66€	
CCMT09T308-FP4PDW WPP20G	0,8	0.08 - 0.20	0.1 - 1.5	4,66€	
DCMT070204-FP4PDW WPP10G	0,4	0.05 - 0.16	0.1 - 1.5	3,98€	
DCMT070204-FP4PDW WPP20G	0,4	0.05 - 0.16	0.1 - 1.5	3,98€	
DCMT11T302-FP4PDW WPP10G	0,2	0.04 - 0.12	0.1 - 1.0	5,56€	
DCMT11T302-FP4PDW WPP20G	0,2	0.04 - 0.12	0.1 - 1.0	5,56€	
DCMT11T304-FP4PDW WPP10G	0,4	0.05 - 0.16	0.1 - 1.5	5,56€	
DCMT11T304-FP4PDW WPP20G	0,4	0.05 - 0.16	0.1 - 1.5	5,56€	
DCMT11T308-FP4PDW WPP10G	0,8	0.08 - 0.20	0.1 - 1.5	5,56€	
DCMT11T308-FP4PDW WPP20G	0,8	0.08 - 0.20	0.1 - 1.5	5,56€	
TCMT06T102-FP4PDW WPP20G	0,2	0.02 - 0.10	0.1 - 1.0	4,04€	
TCMT06T104-FP4PDW WPP20G	0,4	0.04 - 0.17	0.1 - 1.0	4,04€	
TCMT110202-FP4PDW WPP20G	0,2	0.04 - 0.12	0.1 - 1.0	4,42€	
TCMT110204-FP4PDW WPP10G	0,4	0.05 - 0.16	0.1 - 1.5	4,42€	
TCMT110204-FP4PDW WPP20G	0,4	0.05 - 0.16	0.1 - 1.5	4,42€	
VCMT110302-FP4PDW WPP20G	0,2	0.04 - 0.12	0.1 - 1.0	6,74€	
VCMT110304-FP4PDW WPP10G	0,4	0.05 - 0.16	0.1 - 1.5	6,74€	
VCMT110304-FP4PDW WPP20G	0,4	0.05 - 0.16	0.1 - 1.5	6,74€	
VCMT160402-FP4PDW WPP20G	0,2	0.04 - 0.12	0.1 - 1.0	7,76€	
VCMT160404-FP4PDW WPP10G	0,4	0.05 - 0.16	0.1 - 1.5	7,76€	
VCMT160404-FP4PDW WPP20G	0,4	0.05 - 0.16	0.1 - 1.5	7,76€	
VCMT160408-FP4PDW WPP10G	0,8	0.08 - 0.20	0.1 - 1.5	7,76€	
VCMT160408-FP4PDW WPP20G	0,8	0.08 - 0.20	0.1 - 1.5	7,76€	

Absender

Firma

Name

Straße / Hausnr.

PLZ / Ort

Dieses Formular nutzen und gleich per E-Mail bestellen!



Senden

In Kooperation mit:

Bestellen Sie jetzt und nutzen Sie den Aktionsrabatt!



	P	M	K	N	S	H	O
WPP10G	●●		●				
WPP20G	●●		●				
WPP30G	●●	●	●				

Wendeschneidplatte

MP4 - Mittlere Bearbeitung

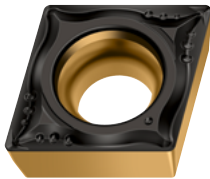

Produktbeschreibung	r [mm]	f [mm]	a _p [mm]	Aktionspreis*	Stückzahl
CCMT060204-MP4PDW WPP10G	0,4	0.08 - 0.20	0.4 - 2.0	4,00€	
CCMT060204-MP4PDW WPP20G	0,4	0.08 - 0.20	0.4 - 2.0	4,00€	
CCMT060208-MP4PDW WPP20G	0,8	0.12 - 0.25	0.5 - 2.0	4,00€	
CCMT09T304-MP4PDW WPP10G	0,4	0.08 - 0.25	0.4 - 3.0	4,66€	
CCMT09T304-MP4PDW WPP20G	0,4	0.08 - 0.25	0.4 - 3.0	4,66€	
CCMT09T308-MP4PDW WPP10G	0,8	0.12 - 0.32	0.5 - 3.0	4,66€	
CCMT09T308-MP4PDW WPP20G	0,8	0.12 - 0.32	0.5 - 3.0	4,66€	
CCMT120404-MP4PDW WPP20G	0,4	0.12 - 0.25	0.4 - 3.5	6,66€	
CCMT120408-MP4PDW WPP20G	0,8	0.12 - 0.32	0.5 - 3.5	6,66€	
DCMT11T304-MP4PDW WPP10G	0,4	0.08 - 0.25	0.4 - 3.0	5,56€	
DCMT11T304-MP4PDW WPP20G	0,4	0.08 - 0.25	0.4 - 3.0	5,56€	
DCMT11T308-MP4PDW WPP10G	0,8	0.12 - 0.32	0.5 - 3.0	5,56€	
DCMT11T308-MP4PDW WPP20G	0,8	0.12 - 0.32	0.5 - 3.0	5,56€	
TCMT110204-MP4PDW WPP20G	0,4	0.08 - 0.20	0.4 - 2.0	4,42€	
TCMT16T304-MP4PDW WPP20G	0,4	0.08 - 0.25	0.4 - 3.0	5,74€	
TCMT16T308-MP4PDW WPP20G	0,8	0.12 - 0.32	0.5 - 3.0	5,74€	
VBMT160404-MP4PDW WPP10G	0,4	0.08 - 0.20	0.4 - 2.0	7,76€	
VBMT160404-MP4PDW WPP20G	0,4	0.08 - 0.20	0.4 - 2.0	7,76€	
VBMT160408-MP4PDW WPP10G	0,8	0.12 - 0.30	0.5 - 2.0	7,76€	
VBMT160408-MP4PDW WPP20G	0,8	0.12 - 0.30	0.5 - 2.0	7,76€	

Absender

Firma

Name

Straße / Hausnr.

PLZ / Ort

Dieses Formular nutzen und gleich per E-Mail bestellen!



Senden

In Kooperation mit:

Bestellen Sie jetzt und nutzen Sie den Aktionsrabatt!



	P	M	K	N	S	H	O
WPP10G	●●		●				
WPP20G	●●		●				
WPP30G	●●	●	●				

Wendeschneidplatte

RP4 - Schruppen

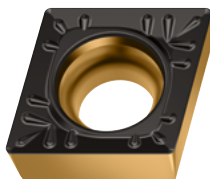

Produktbeschreibung	r [mm]	f [mm]	a _p [mm]	Aktionspreis*	Stückzahl
CCMT060204-RP4PDW WPP20G	0,4	0.12 - 0.25	0.4 - 2.5	4,00€	
CCMT060204-RP4PDW WPP30G	0,4	0.12 - 0.25	0.4 - 2.5	4,00€	
CCMT060208-RP4PDW WPP20G	0,8	0.16 - 0.30	0.6 - 2.5	4,00€	
CCMT060208-RP4PDW WPP30G	0,8	0.16 - 0.30	0.6 - 2.5	4,00€	
CCMT09T304-RP4PDW WPP10G	0,4	0.12 - 0.25	0.4 - 3.0	4,66€	
CCMT09T304-RP4PDW WPP20G	0,4	0.12 - 0.25	0.4 - 3.0	4,66€	
CCMT09T304-RP4PDW WPP30G	0,4	0.12 - 0.25	0.4 - 3.0	4,66€	
CCMT09T308-RP4PDW WPP10G	0,8	0.16 - 0.35	0.6 - 4.0	4,66€	
CCMT09T308-RP4PDW WPP20G	0,8	0.16 - 0.35	0.6 - 4.0	4,66€	
CCMT09T308-RP4PDW WPP30G	0,8	0.16 - 0.35	0.6 - 4.0	4,66€	
CCMT120404-RP4PDW WPP20G	0,4	0.12 - 0.30	0.4 - 4.0	6,66€	
CCMT120404-RP4PDW WPP30G	0,4	0.12 - 0.30	0.4 - 4.0	6,66€	
CCMT120408-RP4PDW WPP10G	0,8	0.16 - 0.40	0.6 - 5.0	6,66€	
CCMT120408-RP4PDW WPP20G	0,8	0.16 - 0.40	0.6 - 5.0	6,66€	
CCMT120408-RP4PDW WPP30G	0,8	0.16 - 0.40	0.6 - 5.0	6,66€	
DCMT11T304-RP4PDW WPP10G	0,4	0.12 - 0.25	0.4 - 3.0	5,56€	
DCMT11T304-RP4PDW WPP20G	0,4	0.12 - 0.25	0.4 - 3.0	5,56€	
DCMT11T304-RP4PDW WPP30G	0,4	0.12 - 0.25	0.4 - 3.0	5,56€	
DCMT11T308-RP4PDW WPP10G	0,8	0.16 - 0.35	0.6 - 4.0	5,56€	
DCMT11T308-RP4PDW WPP20G	0,8	0.16 - 0.35	0.6 - 4.0	5,56€	
DCMT11T308-RP4PDW WPP30G	0,8	0.16 - 0.35	0.6 - 4.0	5,56€	
SCMT09T304-RP4PDW WPP20G	0,4	0.12 - 0.25	0.4 - 3.0	4,66€	
SCMT09T304-RP4PDW WPP30G	0,4	0.12 - 0.25	0.4 - 3.0	4,66€	
SCMT09T308-RP4PDW WPP20G	0,8	0.16 - 0.35	0.6 - 4.0	4,66€	
SCMT09T308-RP4PDW WPP30G	0,8	0.16 - 0.35	0.6 - 4.0	4,66€	
SCMT120408-RP4PDW WPP20G	0,8	0.16 - 0.40	0.6 - 5.0	6,66€	
SCMT120408-RP4PDW WPP30G	0,8	0.16 - 0.40	0.6 - 5.0	6,66€	
TCMT16T304-RP4PDW WPP20G	0,4	0.12 - 0.25	0.4 - 3.0	5,74€	
TCMT16T304-RP4PDW WPP30G	0,4	0.12 - 0.25	0.4 - 3.0	5,74€	
TCMT16T308-RP4PDW WPP20G	0,8	0.16 - 0.35	0.6 - 4.0	5,74€	
TCMT16T308-RP4PDW WPP30G	0,8	0.16 - 0.35	0.6 - 4.0	5,74€	
VCMT110304-RP4PDW WPP20G	0,4	0.12 - 0.20	0.4 - 2.5	6,74€	
VCMT110308-RP4PDW WPP20G	0,8	0.16 - 0.25	0.6 - 3.0	6,74€	
VCMT160404-RP4PDW WPP10G	0,4	0.12 - 0.25	0.4 - 2.5	7,76€	
VCMT160404-RP4PDW WPP20G	0,4	0.12 - 0.25	0.4 - 2.5	7,76€	
VCMT160408-RP4PDW WPP10G	0,8	0.16 - 0.30	0.6 - 3.0	7,76€	
VCMT160408-RP4PDW WPP20G	0,8	0.16 - 0.30	0.6 - 3.0	7,76€	

Absender

Firma

Name

Straße / Hausnr.

PLZ / Ort

Dieses Formular nutzen und gleich per E-Mail bestellen!



Senden

In Kooperation mit:

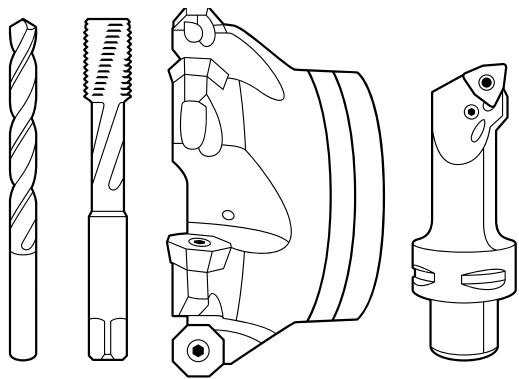

www.walter-tools.com